

HR Series Metering Valve

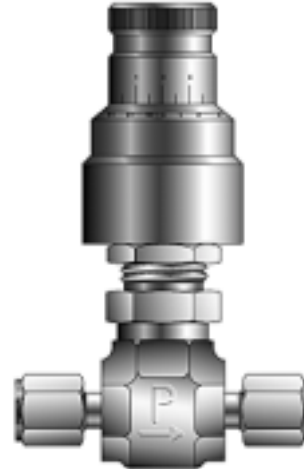

WORKING PRESSURES AND TEMPERATURES

Elastomer	Working Pressure	Temperature Range
Buna-N	250 psig @ 70 °F 1.7 MPa @ 21 °C	-10 °F to 250 °F -23 °C to 121 °C
EPR		-40 °F to 250 °F -40 °C to 121 °C
Neoprene		-40 °F to 250 °F -40 °C to 121 °C
Fluorocarbon		-10 °F to 400 °F -23 °C to 204 °C

Always consult your authorized Parker representative if questions arise.

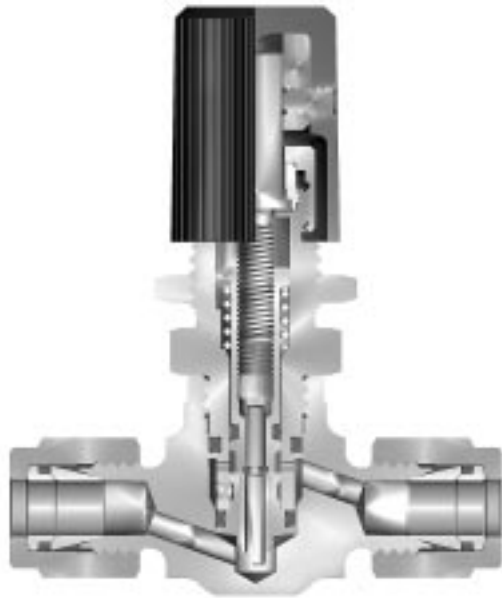

Figure 1: HR Series Metering Valve with Knurled Handle Cross Sectional View

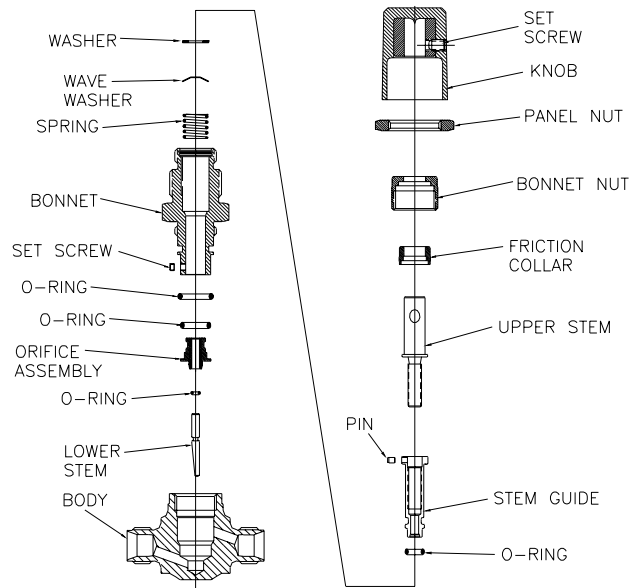

Figure 2: HR Series Metering Valve with Exploded View

DISASSEMBLY

WARNING: MAKE CERTAIN THE SYSTEM IN WHICH THE VALVE IS INSTALLED IS DRAINED AND/OR EXHAUSTED OF ALL PRESSURE BEFORE STARTING VALVE REMOVAL OR DISASSEMBLY. FAILURE TO DO SO CAN CAUSE DEATH, PERSONAL INJURY AND PROPERTY DAMAGE.

1. Verify that the Metering Valve Maintenance Kit being used is appropriate for the Valve's size, Handle and service requirements. Always contact your authorized Parker representative if any questions arise.
2. Turn the Valve to its complete open position.
3. Remove the Cartridge Assembly (with the handle installed) from the Valve Body by turning the Bonnet counter-clockwise with an 11/16 inch hex wrench.
4. Remove the Orifice Assembly from the Cartridge Assembly by turning the Set Screw counter-clockwise with a 0.035 inch allen wrench.

REASSEMBLY

1. Make certain all parts are free of dirt or other contamination before starting reassembly of the Valve.
2. Place the O-Ring onto the Orifice Assembly.
3. Insert the Orifice Assembly onto the Cartridge Assembly.
4. Remove the Orifice Assembly and insure there isn't any loose or hanging material on the inside of the Orifice Assembly or on the Lower Stem.

NOTE: This step is necessary for proper valve function.

5. Re-insert the Orifice Assembly into the Cartridge Assembly.
6. Thread the Set Screw into the Orifice Assembly using a 0.035 inch allen wrench. **INSURE CARE WHEN INSERTING THIS SCREW, OVERTIGHTENING CAN EASILY STRIP THE THREAD.**
8. Insure the valve is turned to its complete open position.
7. Place the Cartridge Assembly into the valve body and using a 11/16 inch hex wrench torque the Bonnet to 25 in-lbs.

VALVE CONNECTOR MAKE-UP INSTRUCTIONS

MALE AND FEMALE PIPE PORTS

Wrench flats are provided on the Valve Body. It is recommended a smooth-jawed wrench or vise be used to grip the Valve Body.

1. On the male threaded part of the connection, apply a high quality pipe joint compound or PTFE tape made for this purpose. When PTFE tape is used, it is recommended two full turns of tape be applied. PTFE tape should not be overhanging or covering the first thread
2. Engage the Valve and the other component part together, until hand-tight.
3. With a proper wrench, holding both the Valve and the component part, continue to tighten to achieve a leak-tight joint.

ULTRASEAL CONNECTIONS

1. Insert the proper O-Ring into the UltraSeal fitting's O-Ring groove. Position the UltraSeal gland sealing face against the O-Ring, and then advance the Nut to a finger-tight position.
2. A positive seal is obtained by advancing the Nut no less than 1/4 turn from the finger-tight position. Proper UltraSeal make-up is achieved when a sharp rise in required application torque occurs, which indicates proper seal face contact and O-Ring seal compression into the UltraSeal groove.

VACUSEAL CONNECTIONS

1. A positive seal is obtained by advancing the Nut 1/8 turn from the finger-tight position.
2. A new gasket should be installed upon each fitting re-make to insure system pressure integrity.

TUBE FITTING CONNECTIONS

1. Insert the tube into the Valve port until the tube bottoms out in the Valve Body. Care should be exercised to insure the tube is properly aligned with the Valve Body and port.
2. Normal make-up for US Customary port sizes 1 thru 3 (1/16 thru 3/16 inch) and SI port sizes 2 thru 4 (2 thru 4 mm) is 3/4 turn from finger tight. Normal make-up for US Customary port sizes 4 thru 16 (1/4 thru 1 inch) and SI port sizes 5 thru 25 (5 thru 25 mm) is 1 1/4 turn from finger tight. For larger port sizes consult Parker Ferrule Presetting Tool Instructions.

PLEASE FOLLOW THE ABOVE DIRECTIONS FOR COUNTING THE NUMBER OF TURNS FOR PROPER FITTING MAKE-UP. DO NOT MAKE-UP TUBE FITTINGS BY TORQUE OR "FEEL". VARIABLES SUCH AS TUBING AND FITTING TOLERANCES, TUBE WALL THICKNESS, AND THE LUBRICITY OF NUT LUBRICANTS CAN RESULT IN AN IMPROPERLY ASSEMBLED TUBE FITTING CONNECTION.

A -Two ferrule A-LOK® compression port



Z -Single ferrule CPI™ compression port



F -ANSI/ASME B1.20.1 Internal pipe threads



V -VacuSeal face seal port



Q -UltraSeal face seal port



M -ANSI/ASME B1.20.1 External pipe threads



WARNING

FAILURE OR IMPROPER SELECTION OR IMPROPER USE OF THE PRODUCTS AND/OR SYSTEMS DESCRIBED HEREIN OR RELATED ITEMS CAN CAUSE DEATH, PERSONAL INJURY AND PROPERTY DAMAGE.

This document and other information from Parker Hannifin Corporation, its subsidiaries and authorized distributors provide product and/or system options for further investigation by users having technical expertise. It is important that you analyze all aspects of your application and review the information concerning the product or system in the current product catalog. Due to the variety of operating conditions and applications for these products or systems, the user, through its own analysis and testing, is solely responsible for making the final selection of the products and systems and assuring that all performance, safety and warning requirements of the application are met.

The products described herein, including without limitation, product features, specifications, designs, availability and pricing, are subject to change by Parker Hannifin Corporation and its subsidiaries at any time without notice.

ALL PARKER VALVES MUST PASS A RIGID OPERATIONAL AND LEAKAGE TEST BEFORE LEAVING THE FACTORY. IT IS RECOMMENDED AFTER ANY REASSEMBLY, THE VALVE SHOULD BE TESTED BY THE USER FOR OPERATION AND LEAKAGE. IF THESE INSTRUCTIONS ARE NOT FULLY COMPLIED WITH, THE REPAIRED PRODUCT MAY FAIL AND CAUSE DAMAGE TO PROPERTY OR INJURY TO PERSONS. PARKER HANNIFIN CANNOT ASSUME RESPONSIBILITY FOR PERFORMANCE OF A CUSTOMER SERVICED VALVE.

